

GOVERNMENT OF ANDHRA PRADESH
DEPARTMENT OF AGRICULTURE
O/o COMMISSIONER & DIRECTOR OF AGRICULTURE,
BASHEERBAGH,OPP.L.B.STADIUM,HYDERABAD.
PHONE NO:040-23383520 (Extn.168), FAX:040-23383529

TENDER NOTICE

No.WD (3)86/2011

Dated: 21-10-2011

Tenders are invited from Companies for construction of new Farm Ponds with 500 Microns Polythene Lining in selected **(6) Districts** of A.P. under the scheme of “Integrated Development of 60000 Pulse Villages in rained Areas” during 2011-12.

Interested Companies are requested to obtain the tender form and tender schedule from the NRM Section of O/o Commissioner & Director of Agriculture, A.P., Hyderabad or obtain the same from the Departmental website <http://agri.ap.nic.in>.

The tender documents can be obtained on payment of Rs.5000 (rupees five thousand only) in the form of DD in favour of Joint Director of Agriculture (NRM), O/o Commissioner and Director of Agriculture, A.P., Hyd. and this amount is not refundable.

1.Sale of tender schedule from Dt.22-10-2011 by 10.30AM To 28-10-2011 by 3.00 PM

2.Last date for submission of sealed tender Dt.28-10-2011 by 5.00 PM

3.Date of opening of the sealed Tender Dt.29-10-2011 by 11.00 AM

Sd/- Dr.Christina Z .Chongthu

Commissioner & Director of Agriculture (i/c)
A.P., Hyd.

GOVERNMENT OF ANDHRA PRADESH
DEPARTMENT OF AGRICULTURE
O/o COMMISSIONER & DIRECTOR OF AGRICULTURE,
BASHEERBAGH, OPP.L.B.STADIUM, HYDERABAD.
PHONE NO:040-23383520 (Extn.168), FAX:040-23383529

TENDER SCHEDULE

Tenders are invited for construction of new farm ponds with 500 microns polythene lining with the following specifications under Integrated development of 60,000 pulse villages in the rain fed areas during 2011-12, in the selected Six (6) Districts of A.P. Estimated cost of each farm pond with following specifications is Rs. 1,20,000/- . Total no. of farm ponds to be executed is : 1247

Specifications:

S.No	Item description	Technical specifications
1	Construction of new farm ponds along with silt trap, inlet, out let (As per the design enclosed) by Hitachi/ TATA /equivalent caterpillar V 200-250 model with long boom of more than or equal to 4m.	Size : 20X20X3 m Top Dimensions: 20X20 m Bottom Dimensions: 11X11 m Side slopes : 1.5:1 Depth : 3 m
2	Polythene Lining of farm ponds (Trenching(0.3 X0.3X0.3 m), Film anchoring and filling soil into trenches)	500 Microns Polythene Lining with dimensions 24 X 25 m
3	Making of Bund (berm) around the farm pond	Bottom width : 1.5 m Top width : 0.5 m Height : 0.5 m Side slopes : 1:1

Tender Process

A. Submission of Details and relevant Documents on the following:

1	Name of the Company	
2	Registered Office address with Telephone / Fax Nos.	
3	Whether Govt. organization / Undertaking / Co-Operative Institution / Private.	
4.	Audit report for the last year and for the present year	
4	Turn over	
5	Details of Earnest Money Deposit (EMD).	
7.	Company Registered Documents	
8	Documents relating to the experience in the field of a.) construction of farm ponds b.) lining of farm ponds	

B.Earnest Money Deposit (EMD):

EMD for an amount of **Rs.30 lakhs** should be deposited. The EMD should be in the form of Demand Draft drawn in favour of Joint Director of Agriculture (NRM), O/o Commissioner & Director of Agriculture , A.P., Hyderabad, or Bank guarantee from any Nationalized bank for Rs **Rs.30 lakhs** in favour of Commissioner & Director of Agriculture,A.P.Hyderabad and enclosed to the bid. **Tender without EMD will be rejected.**

C. COMMERCIAL BID

1	Name of the Company	
2	Rate quoted for Construction of one Farm Pond with 500 microns of polythene sheet lining . (a.) <u>Rate quoted should inclusive of all the taxes, VAT, duties, Cess, insurance, freight charges including loading and unloading charges</u> And (b) <u>Rate should be quoted considering all the items of specifications as a unit).</u>	Rs. In words:

Note: Conditional offer will not be entertained.

Declaration by the tenderer:

I have submitted this bid against notification no..... dated.....and tender terms and conditions of the tender document.

I have gone through the Terms and Conditions governing this tender and rates have been quoted without any ambiguity in my mind and I would abide by the terms and conditions governing this tender.

Place:

Name:

Date:

Signature;

Address with Seal.

D.All terms and conditions stipulated in the tender schedule should invariably signed and enclosed. The tender submitted without enclosing the signed terms and conditions will summarily be rejected.

E. Tender should be kept in a cover (Super scribed as “Tender for construction of new farm ponds with polythene lining”) along with tender schedule duly signed (consisting of terms and conditions) and sealed. The cover should be addressed to the Commissioner & Director of Agriculture, Andhra Pradesh, Hyderabad. All the sealed completed tenders shall be deposited in the sealed tender box kept in the chambers of Additional Director of Agriculture III , O/o. Commissioner of Agriculture, A.P, Hyderabad.

If the tender is sent by post, care should be taken to send by registered post so as to reach this office before the closing date and time. Department is not liable in case of loss of tender document or delay in receipt of the same.

F. If representative is participating, letter of authorization , along with photo of the representative shall be presented in **Schedule- A**, to participate in the tender opening and to participate in negotiation of rates for items tendered, from the person who has signed commercial bids.

G.The tender schedule submitted which is down loaded from the Website <http://agri.ap.nic.in> should invariably accompanied with a DD of Rs 5000/- towards cost of tender schedule. Tender not accompanied with DD will summarily be rejected.

H. Sealed tenders will be opened in presence of State Level Tender Committee. The State Level Tender Committee appointed by C&DA, A.P., Hyderabad will recommend for acceptance or rejection of the tender to the accepting authority i.e., Commissioner and Director of Agriculture, Andhra Pradesh, Hyderabad.

I. Last date for submission of the sealed Tenders: **28/10/2011 by 5.00 P.M.**

2. Date and time of opening of sealed tenders: **29-10-2011 by 11.00 A.M**

Terms and Conditions

- 1). Tender without EMD will be rejected.
- 2). In respect of successful tenderer if the work is done as per the accepted programme the EMD will be refunded after successful implementation of the work order. The EMD is refundable in respect of unsuccessful tenderer after completion of total formality of the tender, placing order with the successful tenderer. However, the EMD is forfeited in the event of successful tenderer, in case, if he does not accept the work order and alternative arrangements will be made for procurement of such product.
- 3) The tender shall be signed only by the proprietor, if it is a proprietary concern. The necessary documents of ownership are to be enclosed.
- 4). If it is a partnership, one of the partners or a person authorized by the partners shall sign the tender. Copy of the partnership deed shall be submitted to know the person authorized to sign the document.
- 5). If it is a public / private limited company, the tender should be executed in the manner laid down in the said company's Articles of Association. The Chief Executive of the company or a person authorized in support of which necessary authorization letter with seal and signature shall be submitted.
- 6). The rate quoted by the company should be valid for one year from the date of agreement. The Department of Agriculture will not entertain any price revision during the validity period of tender.
- 7) On account of escalation in prices of the material in the market due to what so ever be the reason during the period of contract, the successful tenderer will not be entitled on claims due to price variation over and above the rate of approval. The validity period can be extended on mutual terms and conditions.
- 8). All the columns of the tender forms shall be duly, properly and exhaustively filled in., it shall always be written both in figures and words.
- 9). All corrections must be signed by the tenderers.
- 10). The tender floated in the bid will summarily be rejected in case of omission in filling up the cost ,as indicated in the tender from specifically "rates and units".
- 11). The tenders will not be considered unless and until all the documents are properly signed and submitted. Any further technical requirement from the scrutinizing committee is to be submitted within the stipulated time. The original letters and documents and manufacturing licenses (for manufactures only) issued by the competent authority shall be produced for verification of tender committee.

12). Sealed application / tender form submitted in prescribed form purchased either from the Department of Agriculture or down loaded from Website along with cost of tender schedule duly signed shall only be considered. The tender schedule submitted which is down loaded from the Website <http://agri.ap.nic.in> should invariably accompanied with a **DD of Rs 5000/-** towards cost of tender schedule. Tender not accompanied with DD will summarily be rejected.

13). Invitation of tenders shall not confer any right on the tenderer to insist for supply orders.

14). The State Level Tender Committee reserves the right to reject the commercial bid without assigning any reason. However, the tenders shall be rejected if they failed to produce the original documents and manufacturing license(for manufacturers only), etc or due to delay in submission of documents sought for and if the tenderer is defaulter already in previous transactions of Government supplies. In addition to this it may be noted that incomplete bid in any form will be liable for rejection.

15) The work will be assigned to the tenderer based on the lowest rate on the basis of cluster approach in the selected **six (6) Districts** and the work given, must be completed **within four (4)** months from the time of assignment of work.

16) On placement of order and acceptance of assigned work, if the company does not perform its obligation as per the order such company will be black listed and the Department of Agriculture shall reserve all rights to make alternate arrangements for completion of work, from any available source and the difference of higher cost paid if any will be recovered from the defaulting company through appropriate action.

17) If the successful tenderer fails to complete the work both in quantity and quality on the schedule time, the EMD shall be forfeited besides initiating legal action as per law.

18) In case, the work done or the materials used are found to be substandard or defective, the work done or the materials used will be rejected and all payment due will be with held until the matter is settled.

19) The successful tenderer has to pay back value of substandard material used / held and interest at bank / credit rate immediately. If the payment is already made and the successful tenderer will solely held responsible for any consequences arising in the field due to sub-standard materials. Such firms will be black listed for the use of substandard material in the work assigned by the department..

20) After opening of Commercial bid, if it is found that the lowest rate quoted is higher than the estimated unit cost, and not acceptable, the department shall have the right to call for negotiations and fix up rate for construction of new farm ponds with polythene lining with specifications mentioned above.

- 21) If the Department desires to have more than one source of work and depending on the season if the Department of Agriculture may require to complete huge quantity of work in short period in 6 Districts., in view of this , those firms who had filed tender & technically qualified and are willing to do the work at the accepted rate will be given opportunity to undertake the work for the items for which they have tendered subject to the acceptance of terms and conditions.
- 22) The successful tenderers after issuance of rate contract by Commissioner & Director of Agriculture, AP, Hyderabad shall execute an agreement covering the terms and conditions on Rs200/- judicial stamp paper or as per the existing procedure at his cost along with the acceptance letter within 7 days.
- 23) The rates quoted shall be for the work of construction of farm pond with size of 20×20×3M along with lining of 500 microns polythene sheet. If the size of the farm pond is less than the prescribed size, the payment will be fixed depending on the measurements recorded by the concerned ADA (SC). This rate should be inclusive of all taxes, VAT, duties. Cess, insurance, freight including loading and unloading etc., installation, and FOR destination basis to any farm pond site. The rate shall also include inter state taxes if any. The rate should be quoted on APGST / VAT paid basis only.
- 24) The material used under this contract shall confirm to the standards mentioned in the technical specifications in the schedule.
- 25) The Department does not guarantee any definite volume of business in this contract.
- 27) The tenderer shall have the sole responsibility of quality and quantity of work to be done under this tender.
- 28) The purchaser or his representative shall have the right to inspect randomly and test the quantity of the material to ascertain their conformity to the standards of the contract.
- 29) Payment will be made to the firm only after submission of UC signed by the District Joint Director of Agril. concerned ADA(SC) and the beneficiary along with documentation evidence.
- 30) The bidder shall clearly state the previous experience along with a certificate of their experience for supply of the above items in support of it.
- 31) The successful tenderer shall not sublet or assign this contract or any part of it.
- 32) Amounts will be released to the Joint Directors of Agriculture of the concerned Districts, for the payment to the agency (tenderer) for the work done in the Districts, on producing UCs.**
- 33) The Commissioner & Director of Agriculture shall have the right to accept or reject or cancel any or all the tenders without assigning any reasons what so ever.**

J. BIDDING PARAMETER:

The bidder shall quote rates for the construction of new farm ponds along with polythene lining as per the specifications.

The bidder who quotes the lowest rate will be ranked L1 and the rest of the others as L2 and L3 and so on.

The L1 bidder shall be selected but the Authority reserves the right to consult the remaining bidders and approve all of those agreeing for the L1 rates.

K. NEGOTIATIONS:

Authority reserves the right to negotiate the rates quoted by the L1 bidder and finalize the contract and the same will be binding on the bidder. All the remaining bidders agreeing for the L1 rates may be approved.

Legal Jurisdiction:

For the Arbitration for fulfilling the duties set forth in the arbitration clause shall be the Commissioner & Director of Agriculture, Andhra Pradesh, Hyderabad and his decision shall be final and binding. The provisions of Indian Arbitration Act 1940 or any statutory amendment, modifications or re-enactment there of and rules made there under and for the time being in force shall apply to the arbitration proceedings. In case of dispute if any, it shall be subject to the Jurisdiction of courts at Hyderabad only.

Sd/- Dr.Christina Z .Chongthu

Commissioner & Director of Agriculture (i/c)

Andhra Pradesh, Hyderabad.

I have gone through the terms and conditions governing this tender and I would abide by the terms and conditions laid down in the tender schedule for construction of farm ponds along with polythene lining as per the specifications.

Place

Seal &

Date

Signature of the Tenderer

SCHEDULE –A
AUTHORIZATION FORM

To

.....

(Name and address of the purchasee)

Ref: - Your tender schedule No

Wewho are established, experienced and reputable company of is hereby authorize M/s..... (Photo , name and address of the agent) to submit a bid, negotiate (as and if necessary) and conclude the contract with you against your above mentioned Bidding Documents for the above work by us.

No company or firm of individual other than Mr/Mrs..... (name and address of the above agent) is authorized to bid, negotiate and conclude the contract against this specific Bidding Documents for the above work by us.

We hereby extend our full guarantee and warranty as per clause of the General conditions of contract, read with modification, if any in the Terms & Conditions of contract for the work and services offered for construction of farm ponds with polythene lining against this Bidding Documents by the above firm.

Yours faithfully,

.....

.....

.....

(Signature, name and designation)

For and behalf of M/s.....

(Name & address of the company)

Note: - This letter of authorization should be on the letter head of the firm and should be signed by a person competent and having the power of attorney to legally bind the same.

SCHEDULE-B

BANK GUARANTEE

Where as[name of Bidder] (hereinafter called “the Bidder”) has submitted his bid dated[date] for construction of new farm pond with polythene lining(hereinafter called “the bid”)

KNOW ALL PEOPLE by theses presents that We (name of the bank) having registered office at(full address)(hereinafter called “the bank”) are bound unto(name of the purchaser) in the sum of(amount in figures and in words) for which payment well and truly to be ,made to the said purchaser , the bank binds itself, its successors and assign by these presents.

Sealed with Common seal of said bank this day of2011.

THE CONDITIONS of this obligation are:

- 1. If the Bidder
 - i) Withdraws its bid during the period of bid validity specified by the bidder on the bid form ; or
 - ii) Does not accept the correction ,of errors in accordance with the instructions to bidders

OR

If the bidder, having been notified of the acceptance of its bid by the purchaser during the period of bid validity;

- iii) fails or refuses to execute the contract form ,if required’ or
- iv) fails or refuses to furnish the performance security, in accordance with the instructions to Bidders;

we undertake to pay the purchaser upto the above amount upon receipt of its first written demand, with out the purchaser having to substantiate its demand, provided that in its demand the purchaser will note that the amount claimed by it is due to it, owing to the occurrence of one or both of the above mentioned two conditions, specifying the occurred condition or conditions.

This guarantee will remain in force upto and including 60(Sixty) days after the period of bid validity and any demand in respect thereof reach the bank not later than the above date.

Date
Place.....

Signature of the Bank
Seal of the bank

Enclosure

Dimensions of the farm pond

Top dimensions: 20 m x 20 m

Bottom dimensions: 11 m x 11 m

Depth: 3.0 m

Slope: 1.5 :1

Silt Trap Dimensions:

Length and width: 2x2x1.5

Depth: 1.5 m

Inlet structure:

Approach channel

Width of inlet structure: 1m

Length of inlet structure: 3m

Depth 0.5m

Steps

Length: 4.24 m

Width 2 m

Outlet structure

Length of outlet structure: 3m

Width of outlet structure: 1m

Depth 0.5m

All dimensions in meters

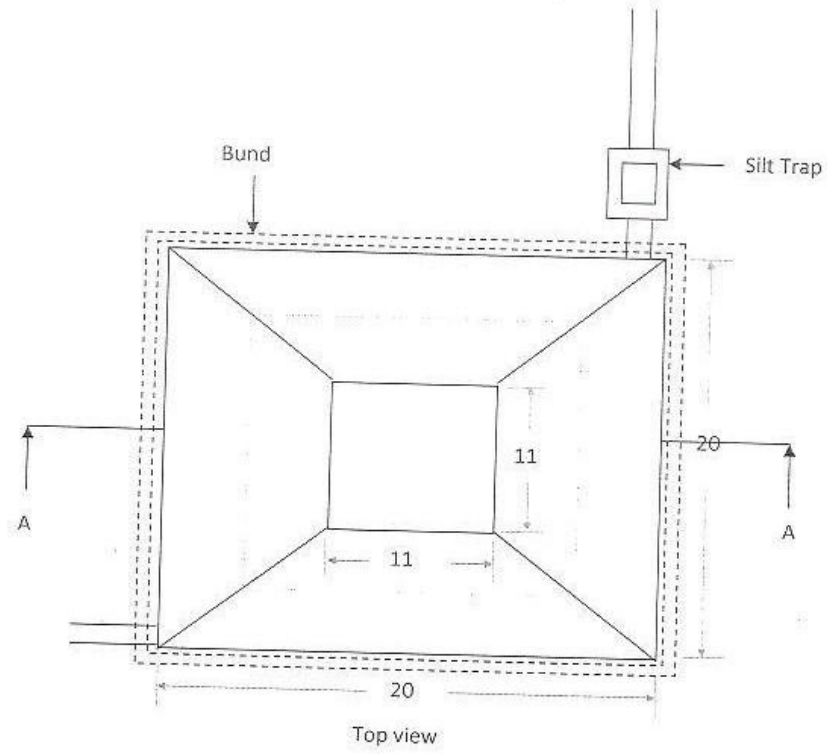

A - A cross sectional view

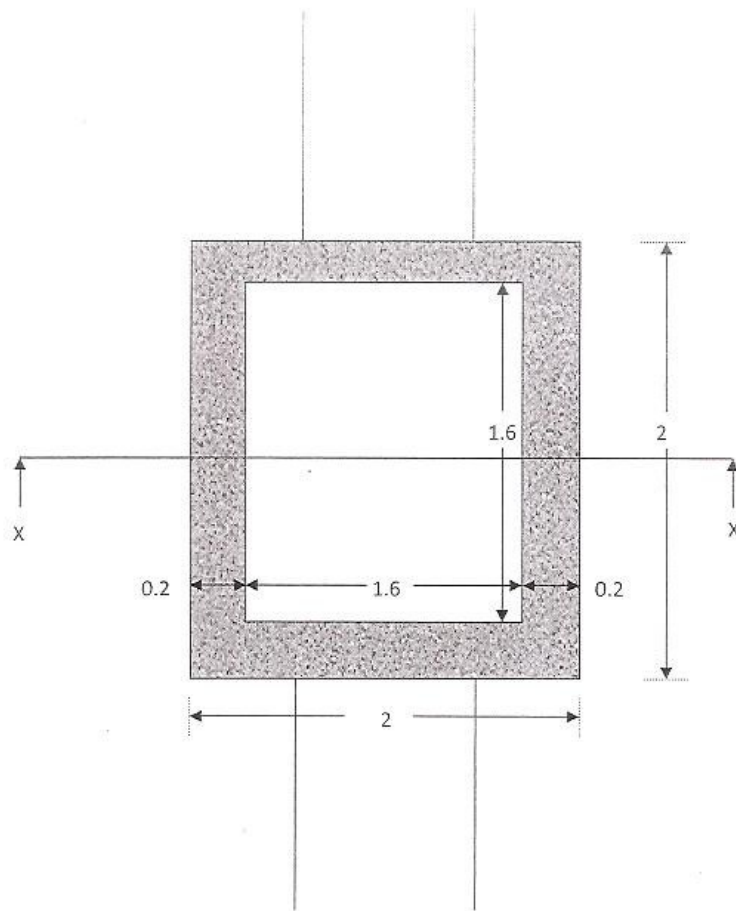

Top view

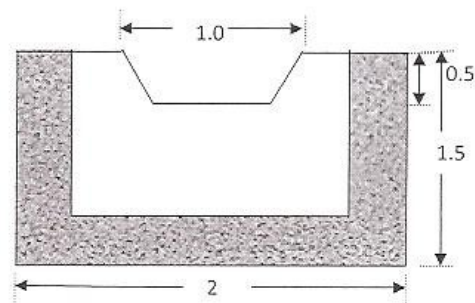

X-X cross sectional view

Fig. Line diagram of silt trap

All dimensions in meters

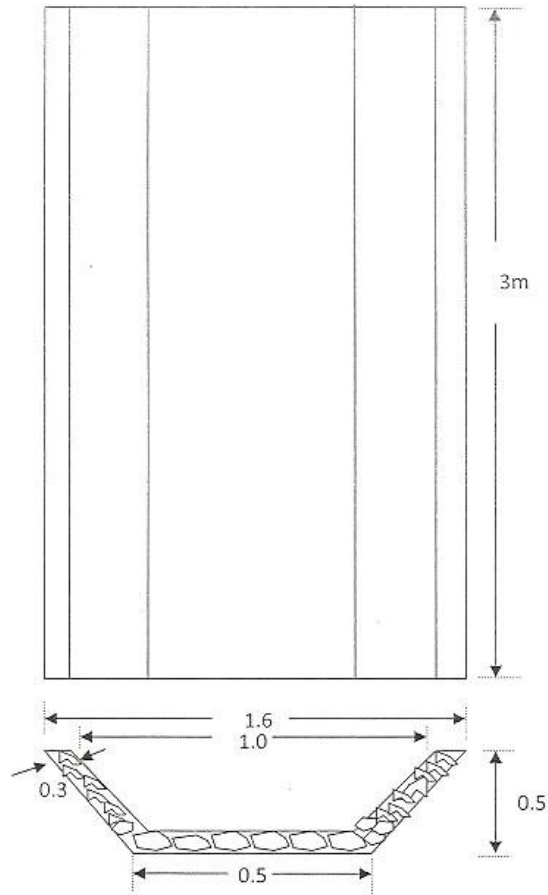

Fig. cross sectional and top view of the channel before silt trap

All dimensions in met

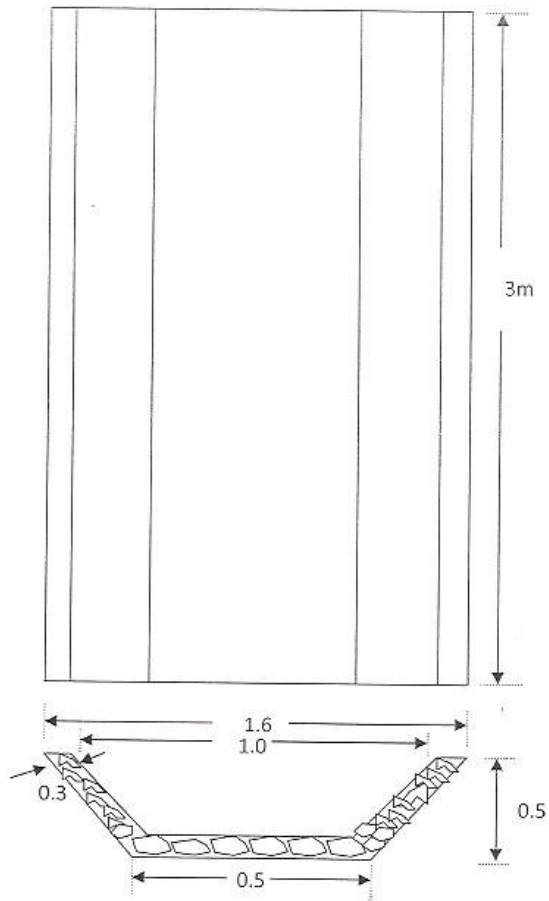

Fig. cross sectional and top view of the out let channel

All dimensions in meters

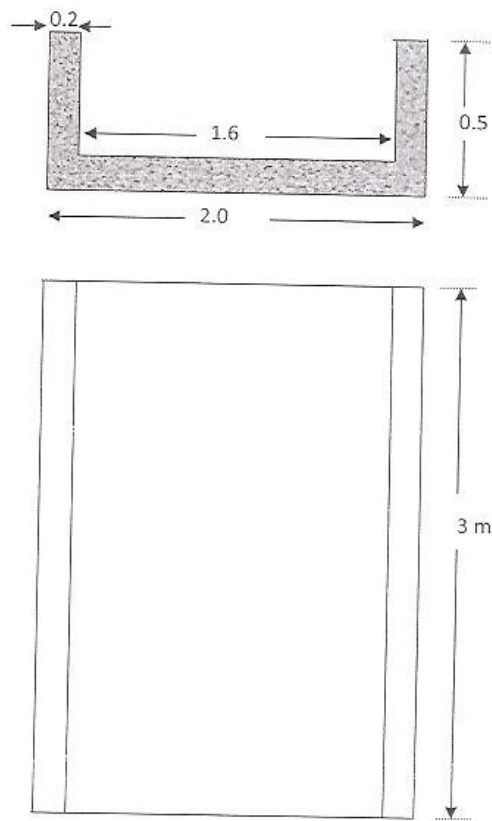

Fig. cross sectional and top view of the approach channel of the inlet

